

Current-Limit Circuit for the Buck Regulator

This article demonstrates how to achieve current limit for the MAX1692 PWM step-down regulator by using a MAX4173H current-sense amplifier.

Additional Information: [Quick View Data Sheet for the MAX1692](#)
[Quick View Data Sheet for the MAX4173](#)
[Samples and Literature Order Form](#)
Powerhelp@design.maxim.com

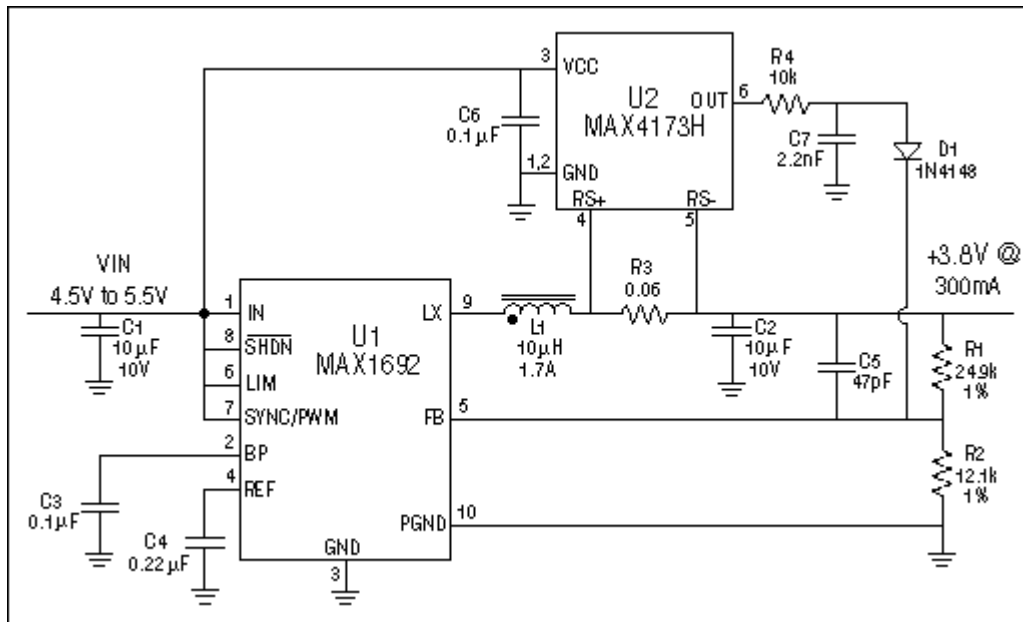

A current limit can be added to a step-down converter by using a MAX4173H current-sense amplifier to inject current into the feedback network. D1 sharpens the threshold of current limit by converting the current sense feedback signal from linear to exponential. This current-limit circuit can be scaled for any output current by adjusting R3. In this case, the MAX1692 provides up to 600mA output and the MAX4173H limits the output current by decreasing the output voltage for output current above 300mA.

IL (mA)	VOUT (V)
0	3.827
100	3.729
200	3.701
258	3.637 (-5%)
300	3.503
312	3.444 (-10%)
347	3.254 (-15%)
380	3.062 (-20%)
400	2.951
414	2.862 (-25%)
450	2.630
500	2.305
550	1.977
600	1.732

December 2000

MORE INFORMATION

MAX1692: [QuickView](#) -- [Full \(PDF\) Data Sheet \(160k\)](#)

-- [Free Sample](#)